

Features

MAPNET II addressable module providing a supervised input and a control relay output in one compact package:**

- Low power latching relay design allows MAPNET II communications to supply both data and module power
- Module uses two sequential addressable points with point designation requiring only one address selection
- For use with Simplex® fire alarm control panels that provide MAPNET II addressable communications
- UL listed to Standard 864

Supervised input point:

- Monitors status of normally open, dry contacts for normal, open, and contact closure
- Operation reports to the MAPNET II channel as a non-latching, supervised Individual Addressable Module (IAM)

Output control relay:

- Power limited rating: 2 A @ 30 VDC, resistive; 1 A @ 30 VDC, inductive
- Non-Power limited rating: 1/2 A @ 120 VAC, resistive; 1/4 A @ 120 VAC, inductive
- Operation reports to the MAPNET II channel as a Control Zone Adapter Module (ZAM)

Compact, sealed construction:

- Enclosed design minimizes dust infiltration
- Mounts in standard 4" square electrical box

Description

2-Point I/O Module. The 2190-9173, 2-Point I/O module allows a Simplex MAPNET II communication channel to monitor an input contact closure and control an output relay from a single compact module. Module power is supplied from the MAPNET II communications channel, eliminating the need for separate power wiring.

Independent Operation. The input and output are independent and operation is controlled by the host panel programming selection. Points may be directly associated to each other such as monitoring the status of the function controlled by the contacts, or may be programmed for unrelated operation.

* This product has been approved by the California State Fire Marshal (CSFM) pursuant to Section 13144.1 of the California Health and Safety Code. See CSFM Listing 7300-0026:223 for allowable values and/or conditions concerning material presented in this document. It is subject to re-examination, revision, and possible cancellation. Accepted for use – City of New York Department of Buildings – MEA35-93E. Additional listings may be applicable; contact your local Simplex product supplier for the latest status. Listings and approvals under Simplex Time Recorder Co. are the property of Tyco Safety Products Westminster.

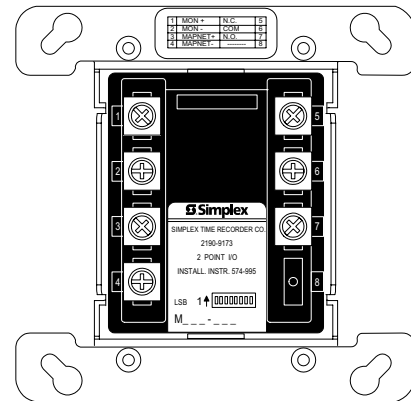

2190-9173, 2-Point I/O Module
(shown approximately 1/2 size)

Typical Applications

Efficient Package. For smoke control applications, this module provides an efficient package for fan damper control with feedback. The monitor point connects to a fan position indicator switch allowing the host panel to track the fan damper status with respect to the requested fan control operation.

General Applications. The monitor and control points can be applied for a variety of associated or independent operations. Flexible programming abilities at the host panel can provide the association logic required for a wide variety of fire or utility operations.

Specifications

Communications and Power	Supplied by MAPNET II, two addresses are required per module
Wiring Information	Refer to diagram on page 2
Address Assignment (Two Addresses Required)	Module address setting selects an even number address for the input point and the next sequential (odd) number address is automatically assigned to the control point
Wire Connections	Screw terminals for in/out wiring, 18 to 12 AWG wire (0.82 to 3.31 mm ²)
Dimensions	4-1/8" H x 4-1/8" W x 1-3/8" D (105 mm x 105 mm x 35 mm)
Housing Material	Black thermoplastic
Mounting Plate Material	Sheet metal, galvanized
Temperature Range	32° F to 120° F (0° C to 49° C) intended for indoor operation
Humidity Range	Up to 93% RH at 100° F (38° C)

** MAPNET II addressable communications are protected by U.S. Patent No. 4,796,025.

Wiring Reference

Maximum Distance to Monitored Contacts:

1. For internal wiring run, no overvoltage protector, 500 ft (152m).
2. For wiring external to building using a 2081-9044 overvoltage protector, 400 ft (122 m).

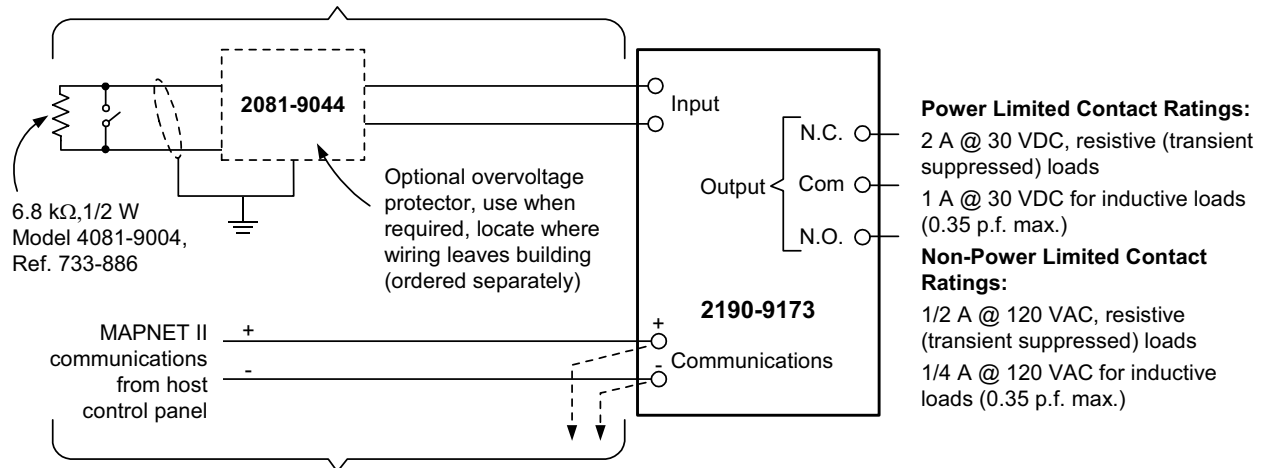

MAPNET II Wiring Distances:

1. Up to 2500 ft (762 m) from host control panel.
2. Up to 10,000 ft (3048 m) total wiring distance, including "T" taps.

NOTE: Refer to Installation Instructions 574-995 and Field Wiring Diagrams 841-804 and 841-996 for detailed installation information.

Mounting Information

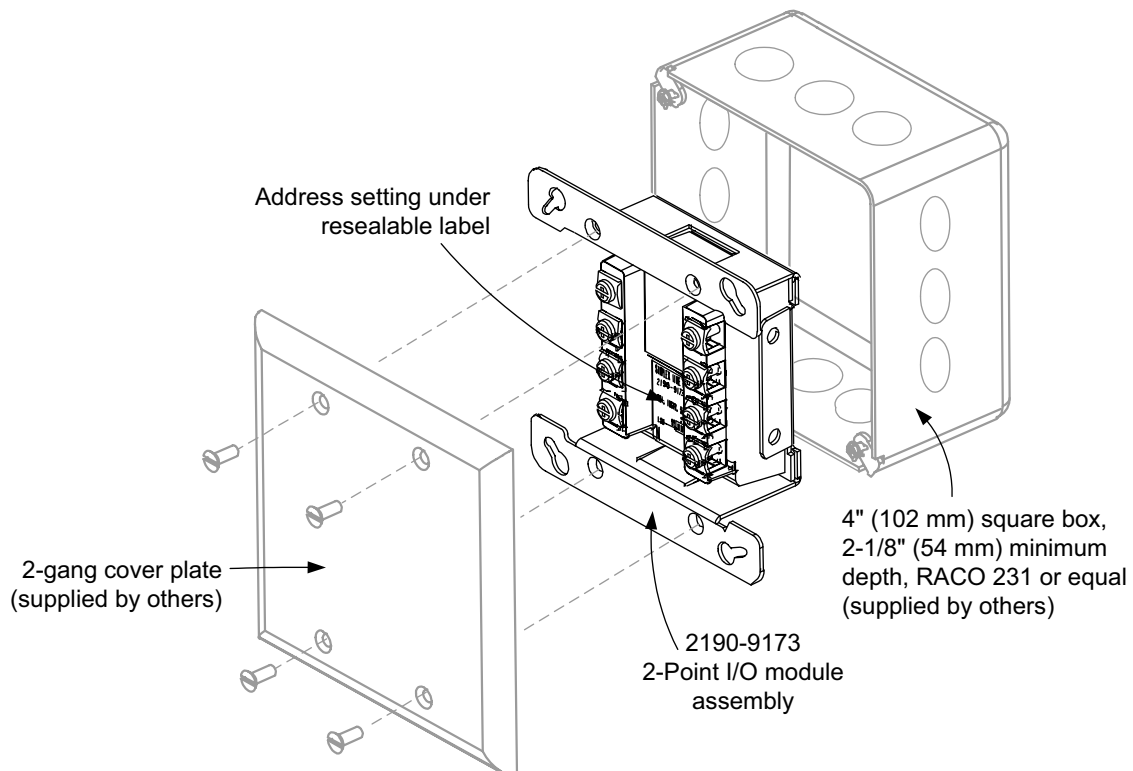

Tyco, Simplex, the Simplex logo, and MAPNET II are trademarks of Tyco International Services AG or its affiliates in the U.S. and/or other countries.



Tyco Safety Products Westminster • Westminster, MA • 01441-0001 • USA
www.tycosafetyproducts-usa-wm.com

S2190-0022-2 1/2006

© 2006 Tyco Safety Products Westminster. All rights reserved. All specifications and other information shown were current as of document revision date and are subject to change without notice.