

Features

TrueAlarm photoelectric sensing *and* TrueAlarm thermal sensing combined in one housing:

- TrueAlarm photoelectric technology accurately monitors for smoke activity
- TrueAlarm thermal sensing accurately monitors for fixed temperature and rate-of-rise temperature, selected or combined as required per sensor
- Basic operation is UL listed to Standard 268
- Sounder operation is also listed to UL Standard 464 as an audible notification appliance

Multi-Sensor Standard Base 4098-9796 provides:

- Two sequentially addressed points, automatically assigned with one address selection
- Connections for remote LED or LED tracking relay for remote alarm status indication

Multi-Sensor Sounder Base 4098-9795 provides the features of 4098-9796 and also provides:

- Built-in piezoelectric sounder with high output (88 dBA) and low current requirements (20 mA)
- Sounder power can be from 24 VDC or from a compatible Notification Appliance Circuit (NAC)
- Sounder output can be synchronized via communications or by the NAC, if NAC powered**
- Sounder operation can be independently activated from the host control panel

TrueAlarm analog sensing operation:

- Analog sensor information is digitally communicated to the control panel via IDNet or MAPNET II two-wire communications
- Individual sensor information is processed by the host control panel to determine sensor status

For use with the following Simplex® products:

- Model Series 4008, 4010, 4100ES, 4010ES, and 4100U fire alarm control panels
- Note: 4008 Series fire alarm control panels provide a reduced feature set, refer to data sheet S4008-0001
- Legacy models 4020/4100/4120 Series fire alarm control panels, and Universal Transponders equipped for MAPNET II operation
- For use with 4100ES, 4100U, or 4010ES control panels, multi-sensor 4098-9754 is also available using single address bases; refer to data sheet S4098-0024 for more information, including TrueSense early fire detection operation combining photo and heat inputs

Functional and architecturally styled enclosures are for ceiling or wall mounting:

- Smoke sensor louver design directs air flow to chamber, enhancing smoke capture
- Sound louvers on sounder base exit both front and side for high output sound
- Built-in magnetic test feature alarms both addresses
- Designed for EMI compatibility
- Optional accessories include remote alarm LED indicator or alarm LED tracking relay

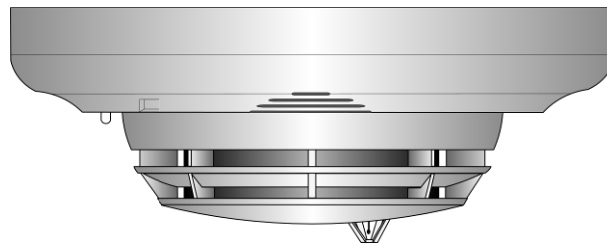

TrueAlarm Multi-Sensor 4098-9754 Mounted in
Multi-Sensor Sounder Base 4098-9795

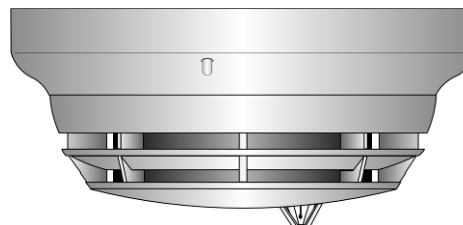

TrueAlarm Multi-Sensor 4098-9754 Mounted in
Multi-Sensor Base 4098-9796

TrueAlarm Multi-Sensor Description

TrueAlarm multi-sensor 4098-9754 combines the established performances of a TrueAlarm photoelectric smoke sensor with a fast-acting and accurate TrueAlarm thermal sensor to provide both features in a single sensor/base assembly.

Digital Communication of Analog Sensing.

Analog information from each sensor is digitally communicated to the control panel where it is analyzed. Photoelectric sensor input is stored and tracked as an average value with an alarm or abnormal condition being determined by comparing the sensor's present value against its average value. Thermal data is processed to look for absolute or rate-of-rise temperature as desired.

Intelligent Data Evaluation. Monitoring each photoelectric sensor's average value provides a software filtering process that compensates for environmental factors (dust, dirt, etc.) and component aging, providing an accurate reference for evaluating new activity. The result is a significant reduction in the probability of false or nuisance alarms caused by shifts in sensitivity, either up or down.

* This product has been approved by the California State Fire Marshal (CSFM) pursuant to Section 13144.1 of the California Health and Safety Code. See CSFM Listing 7300-0026:217 for allowable values and/or conditions concerning material presented in this document. It is subject to re-examination, revision, and possible cancellation. Accepted for use – City of New York Department of Buildings – MEA35-93E. Additional listings may be applicable; contact your local Simplex product supplier for the latest status. Listings and approvals under Simplex Time Recorder Co. are the property of Tyco Fire Protection Products.

** Total quantity of sounder bases available for coding on the same communications channel may vary with panel application and availability of NAC power. Refer to specific control panel requirements.

Description (Continued)

Control Panel Selection. Peak activity per sensor is stored to assist in evaluating specific locations. The alarm set point for each TrueAlarm sensor is determined at the control panel, selectable as more or less sensitive as the individual application requires.

Timed/Multi-Stage Selection. Alarm set points can be programmed for timed automatic sensitivity selection (such as more sensitive at night, less sensitive during day). Control panel programming can also provide multi-stage operation per sensor. For example, a 0.2% level may cause a warning to prompt investigation while a 2.5% level may initiate an alarm.

Sensor Alarm and Trouble LED Indication. Each sensor base's LED pulses to indicate communications with the panel. If the control panel determines that a sensor is in alarm, or that it is dirty or has some other type of trouble, the details are annunciated at the control panel and that sensor base's LED will be turned on steadily. During a system alarm, the control panel will control the LEDs such that an LED indicating a trouble will return to pulsing to help identify the alarmed sensors.

TrueAlarm Analog Sensor Features

Sealed against rear air flow entry

Electronics are EMI/RFI shielded

Smoke sensing:

- Photoelectric sensing technology
- 360° smoke entry for optimum response
- Chamber screen provides protection from dirt, dust, and insects

Heat sensing:

- Fast response thermistor design
- Rate compensated, self-resetting operation
- Control panel can select per sensor for fixed temperature sensing, rate-of-rise temperature sensing, or the combination of both

Photoelectric Sensing

TrueAlarm photoelectric sensors use a stable, pulsed infrared LED light source and a silicon photodiode receiver to provide consistent and accurate low power smoke sensing. Seven levels of sensitivity are available for each individual sensor, ranging from 0.2% to 3.7% per foot of smoke obscuration. Sensitivity is selected and monitored at the fire alarm control panel.

The sensor head design provides 360° smoke entry for optimum smoke response. Because of the photoelectric sensing technology, the 4098-9754 sensor is UL listed for air velocity of up to 4000 ft/min. However, care must be taken in determining sensor locations to avoid areas where local airflow may also impact any smoke flow. (Refer to the application reference section on this page.)

Heat Sensing

TrueAlarm heat sensors monitor a fast reacting thermistor providing operation that is self-restoring and rate compensated. Due to its small thermal mass, the sensor accurately and quickly measures the local temperature for analysis at the fire alarm control panel. The control panel allows alarm selection to be per sensor as fixed temperature, or rate-of-rise temperature, or the combination of both.

Rate-of-rise temperature detection is selectable at the control panel for either 15° F (8.3° C) or 20° F (11.1° C) per minute. Fixed temperature sensing is independent of rate-of-rise sensing and selectable to operate at 135° F (57.2° C) or 155° F (68° C). In a slow developing fire, the temperature may not increase rapidly enough to operate the rate-of-rise feature. However, an alarm will be initiated when the temperature reaches its selected fixed temperature setting.

TrueAlarm heat sensors can be programmed as a utility device to monitor for temperature extremes in the range from 32° F to 122° F (0° C to 50° C). This feature can provide freeze warnings or alert to HVAC system problems. (Refer to specific panels for availability.)

Application Reference

Sensor locations should be determined after careful consideration of the physical layout and contents of the area to be protected. Refer to NFPA 72, the *National Fire Alarm and Signaling Code*. On smooth ceilings, smoke sensor spacing of 30 ft (9.1 m) may be used as a guide. For detailed application information, refer to 4098 *Detectors, Sensors, and Bases Application Manual*, Part Number 574-709.

Installed Dimension Reference

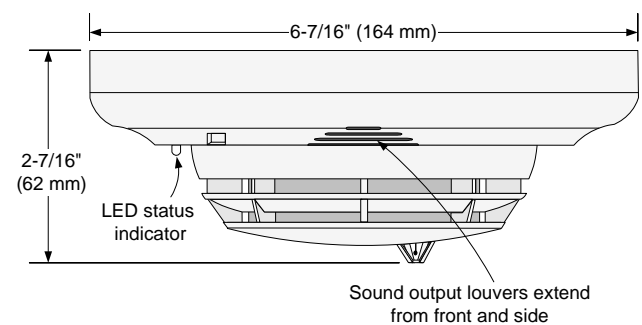

Multi-Sensor with 4098-9795 Multi-Sensor Sounder Base

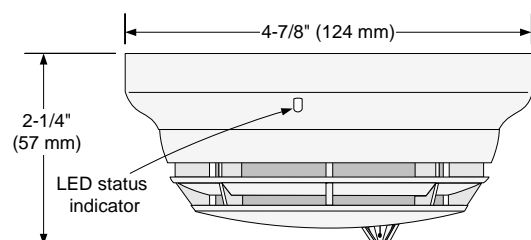

Multi-Sensor with 4098-9796 Multi-Sensor Base

Multi-Sensor Base Features

Base mounted address selection allows the addresses of the multi-sensor base to remain with its programmed location when the sensor is removed for service.

Integral red LED indicates power-on by pulsing, or alarm or trouble when steady on, reflecting status of either sensor. The exact status of the specific sensing element is announced at the fire alarm control panel.

Fire Alarm Control Panel Features

- Individual smoke sensitivity and temperature operation is selectable for each sensor

Mounting Reference

Fire Alarm Control Panel Features (Cont'd)

- Sensitivity monitoring that satisfies NFPA 72 sensitivity testing requirements
- Peak value logging allows accurate analysis for sensitivity selection
- Automatic, once per minute individual sensor calibration check verifies sensor integrity
- Multi-stage alarm operation
- Selectable alarm verification
- Ability to correlate sensitivity selection with temperature
- Automatic environmental compensation
- Smoke sensitivity displayed in percent per foot
- Ability to display and print detailed sensor information in plain English language

Electrical boxes are supplied by others, refer to notes below for additional information

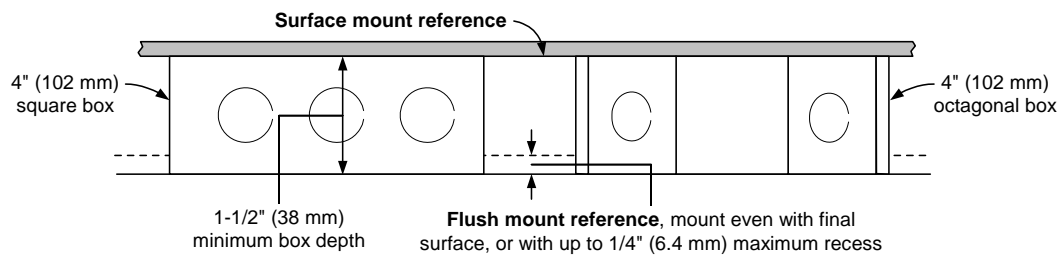

Optional 4098-9822 Relay

(Mounts in base electrical box and requires additional volume, see notes 1 and 2 below)

Relay size:
2-1/2" X 1-1/2" X 1"
(64 mm X 38 mm X 25.4 mm)
(3.75 cubic inches)

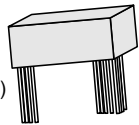

4098-9796 Multi-Sensor Base Mounting

4098-9832 Adapter Plate, required for mounting to surface mounted boxes and 4" square flush box

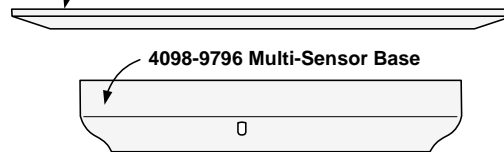

4098-9795 Multi-Sensor Sounder Base Mounting

For 4098-9795 only, when using 4" square box flush mount, a single gang adapter plate (RACO No. 787 or equal, by others) is required

4098-9832 Adapter Plate, required for mounting to surface mounted boxes (mounts inverted)

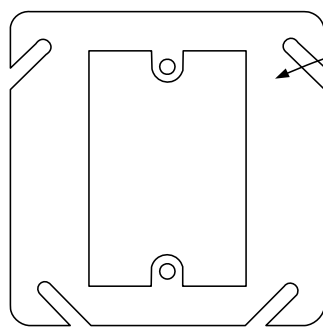

4098-9754 Multi-Sensor

NOTES:

1. Review wire size, wire count, box type, and whether 4098-9822 relay is used before determining box size.
2. When 4098-9822 relay is used, mount relay in electrical box and use 1-1/2" extension ring (by others) on 4" square or octagonal box of 1-1/2" or 2-1/8" depth as required.
3. Flush mounting also fits a single gang box, 2-1/8" (51 mm) deep if compatible with wiring requirements. (Not applicable if 4098-9822 relay is used.)
4. Refer to Installation Instructions 574-707 for additional information.

Product Selection Chart

TrueAlarm Multi-Sensor (ordered separately, refer to page 3 for mounting requirements)

| Model | Description |
|-----------|-------------------------------------------------------------------------------------------------------------|
| 4098-9754 | Multi-sensor, photoelectric sensor with integral thermal sensor, for use with bases 4098-9795 and 4098-9796 |

TrueAlarm Multi-Sensor Bases (ordered separately, refer to page 3 for mounting requirements)

| Model | Description |
|-----------|----------------------|
| 4098-9795 | <u>Sounder Base</u> |
| 4098-9796 | <u>Standard Base</u> |

Dual address base for multi-sensor 4098-9754; with connections for remote LED alarm indicator **or** unsupervised relay

Accessories (ordered separately as required, refer to page 3 for additional mounting requirements)

| Model | Description |
|-----------|----------------------------------------------------------------------------------------------------------------------------|
| 4098-9832 | Adapter Plate, 6-3/8" (162 mm) diameter, 1/4" (6.4 mm) deep, matches bases, required for some mounting combinations |
| 2098-9808 | Choose one if required |
| 4098-9822 | |

Red LED Alarm Indicator on single gang stainless steel plate, mounts on single gang box, 1-1/2" minimum depth

Relay with operation that tracks base LED status, mounts in base electrical box, 4" square or octagonal box with 1-1/2" (38 mm) extension ring, select box depth per actual wiring requirements

Specifications

General Operating Specifications

| | | |
|-----------------------------------------------------------|--------------------------------------------------------------------------------------------------------------------------------------------------------------------------------------------------------------------------------------------------------|-----------------------------------------------------------------------|
| Communications and Sensor Supervisory Power | IDNet or MAPNET II communications, auto-select, 24-40 VDC w/data, 400 μ A typical, supplied by control panel, 2 addresses per base | |
| Communications and Sounder Power Connections | Screw terminals for in/out wiring, 18 to 14 AWG | |
| Remote LED Alarm Indicator | Current | 1 mA typical supplied from communications, no impact to alarm current |
| | LED Connections | Color coded wire leads, 18 AWG |
| UL Listed Temperature Range | 32° F to 100° F (0° C to 38° C) | |
| Operating Temperature Range | 15° F to 122° F (-9° C to 50° C) | |
| Humidity Range | 10 to 95% RH | |
| Smoke Sensor Sensitivity Range | 0.2 % to 3.7% per foot of smoke obscuration, selectable at host control panel | |
| Smoke Sensor Air Velocity Range | 0-4000 ft/min (0-1220 m/min) | |
| Thermal Sensor Operation (selected at host control panel) | Fixed alarm temperature setting of 135° F (57.2° C), and/or rate-of-rise temperature alarm at 15° F (8.3° C) or 20° F (11.1° C), also selectable as utility monitoring operation from 32° F to 122° F (0° C to 50° C), availability is panel dependent | |
| Sensor, Bases, and Adapter Plate Color | Frost White | |

Sounder Operation with 4098-9795 Multi-Sensor Sounder Base

| | | |
|----------------------------------------|-------------------------------------------------------------------------------------------------------------------------------------------------------------------------|----------------------------------------------------------------------------|
| Sounder Voltage | 18 to 32 VDC from steady external source or from NAC | |
| Alarm Current (sounder on) | 20 mA @ 24 VDC, 24 mA maximum @ 32 VDC | |
| Sounder Output | 88 dBA minimum @ 10 ft (3 m) per UL Standard 464, <i>Audible Signaling Appliances</i> and UL Standard 268, <i>Smoke Detectors for Fire Protective Signaling Systems</i> | |
| Sounder Power Supervision (selectable) | Supervised | Select for continuous 24 VDC power, loss of power is communicated to panel |
| | Unsupervised | Select when connected to NAC for sounder power, NAC provides supervision |
| NAC Powered Operation | When sounder is activated by control panel, sounder output tracks connected NAC to allow synchronized coding (Temporal or March Time, etc.) | |

4098-9822 Unsupervised Relay Option

| | |
|---------------------------------------------------------------|-----------------------------------------------------------------------|
| Externally Supplied Relay Voltage | 18-32 VDC, steady source recommended (connects to remote LED leads) |
| Alarm Current | 13 mA from separate 24 VDC supply |
| Contact Ratings, DPDT contacts for resistive/suppressed loads | Power limited rating: 2 A @ 30 VDC |
| | Non-power limited rating: 1/2 A @ 120 VAC |
| Relay Operation | Tracks base LED status, relay is on with trouble or alarm at the base |

TYCO, SIMPLEX, and the product names listed in this material are marks and/or registered marks. Unauthorized use is strictly prohibited. NFPA 72 is a registered trademark of the National Fire Protection Association (NFPA).



Tyco Fire Protection Products • Westminister, MA • 01441-0001 • USA

S4098-0033-5 9/2012

www.simplexgrinnell.com

© 2012 Tyco Fire Protection Products. All rights reserved. All specifications and other information shown were current as of document revision date and are subject to change without notice.