

Features

Combine a Simplex visible notification appliance (strobe) with a compatible audible notification appliance:

- Strobes are typically mounted below the audible appliance (often required with large diameter bells that extend upward from the striking mechanism)
- Where appropriate, strobes can be mounted above the audible appliance

Compatible Simplex strobes are available with the following features:

- Intensity is available as 15 Cd, 30 Cd, or 110 Cd
- Strobes have red housings with white “Fire” lettering
- Refer to data sheet S4904-0008 for additional strobe information

Strobes and audible notification appliances are ordered separately

Two versions are available:

- **4905-9921** is for semi-flush mounting on 4” (102 mm) square electrical boxes
- **4905-9925** is for surface mounting on Simplex 2975-9145 boxes

Modular design allows strobe to be paired with a variety of audible notification appliances to suit local requirements

UL Listed to Standard 464

Description

Standard Simplex 4903 series audible/visible appliances combine high intensity strobes with integral horns and speakers. For special applications requiring bells, chimes, or other audible notification appliances, these modular adapters allow a separate 4904 series visible notification appliance to be mounted on the same electrical box as the required audible notification appliance.

Model 4905-9921 is for semi-flush mount using standard 4” square electrical boxes.

Model 4905-9925 is for surface mount using the Simplex 2975-9145 box.

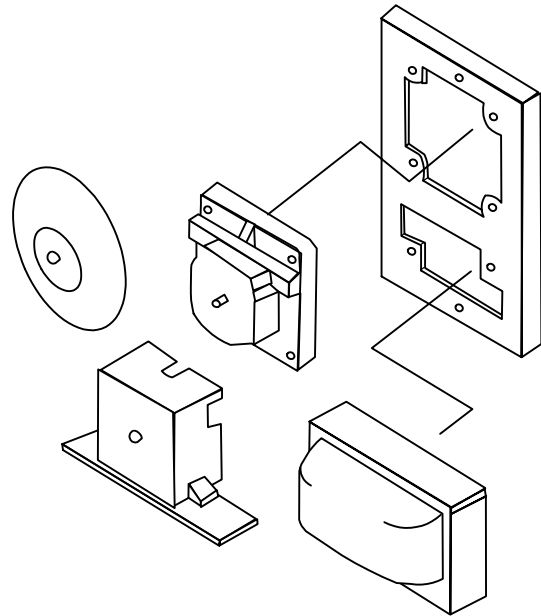

Modular Adapter Installation Reference

Specifications

Metal Thickness	0.060" (1.52 mm)
Metal Finish	Painted red

4905-9921 Specifications and Reference

Dimensions	8-1/4" H x 5-3/4" W x 3/8" D (210 mm x 146 mm x 9.5 mm)
Box Size	4" (102 mm) square
Box Depth	1-1/2" (38 mm) minimum; refer to audible appliance for required box depth

4905-9925 Specifications and Reference

Dimensions	8-3/16" H x 5-7/16" W x 3/8" D (208 mm x 138 mm x 9.5 mm)
2975-9145 Box Dimensions	7-7/8" H x 5-1/8" W x 2-3/4" D (200 mm x 130 mm x 70 mm)

* This product was not ULC listed or approved by FM, MEA (NYC), or CSFM as of document revision date. Additional listings may be applicable; contact your local Simplex product supplier for the latest status. Listings and approvals under Simplex Time Recorder Co. are the property of Tyco Safety Products Westminster.

4905-9921 Installation Reference

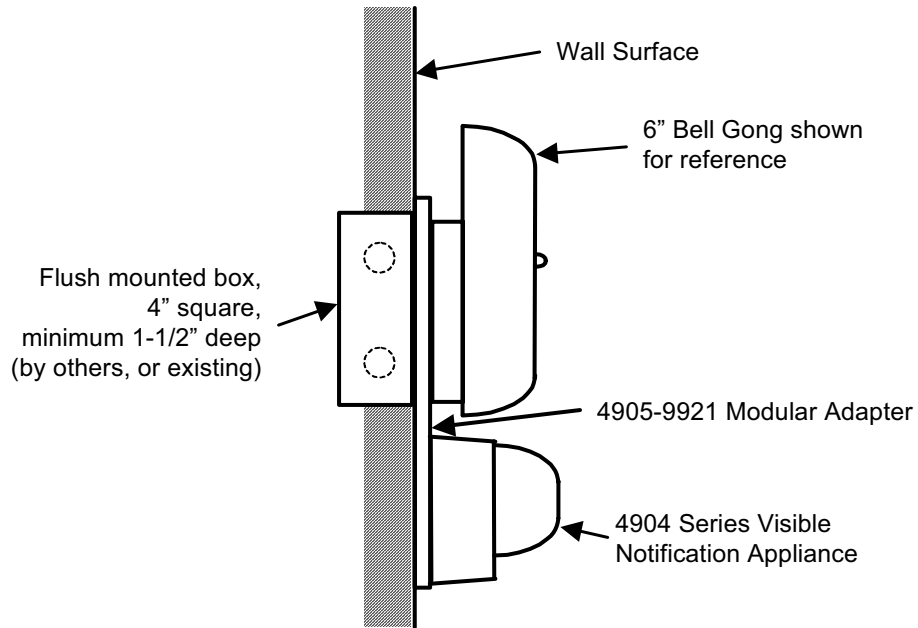

4905-9925 Installation Reference

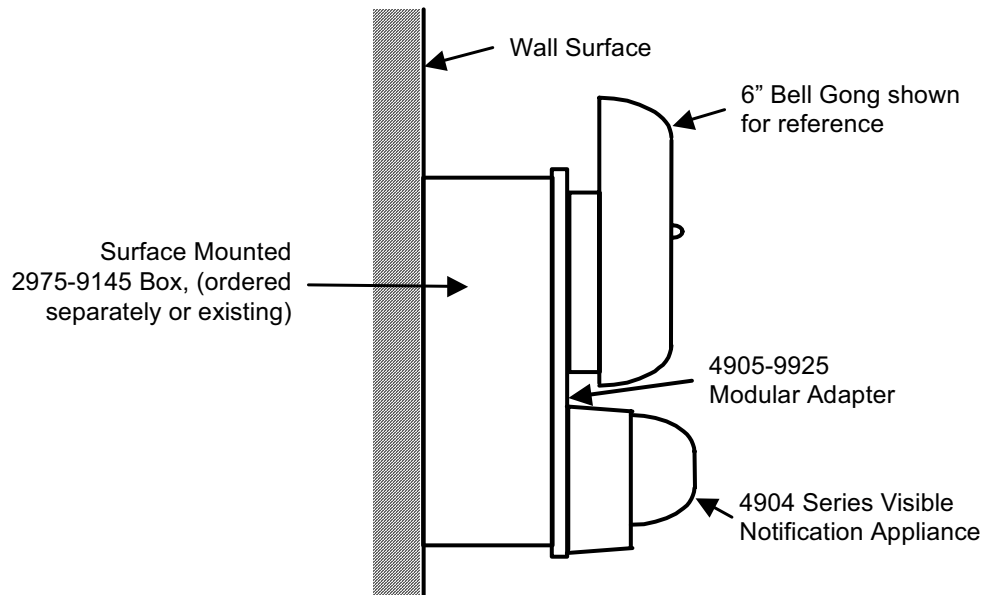

Tyco, Simplex, and the Simplex logo are trademarks of Tyco International Services AG or its affiliates in the U.S. and/or other countries.