

Features

Xenon flashtube visible notification appliance (strobe):

- UL listed to Standard 1971
- Models are available with 15, 30, or 110 candela
- 24 VDC operation with switch selection for free-run or synchronized flash rate, also compatible with SmartSync™ strobe operation**
- Compatible with ADA requirements
- Strobe candela rating is clearly indicated on reflector
- Diode polarized input for connection to reverse polarity, supervised Notification Appliance Circuit (NAC)
- Rugged, high impact, flame retardant thermoplastic housing

Synchronized flash rate mode for use with:

- Simplex® fire alarm control panel NACs that provide strobe synchronization or SmartSync notification appliance two-wire control
- Separate Synchronization modules for Class B (Style Y) or Class A (Style Z) operation
- SmartSync Control Module 4905-9938

Housing options:

- Red with white “FIRE”
- White without lettering
- Red wire guard is available*

Description

Simplex 4904 Series ceiling mount visible notification appliances provide symmetrical light output in key axis directions by utilizing a compound, multi-surface reflector design. The lens assembly fits securely into its housing, providing a high integrity notification appliance that is impact and vandal resistant and suitable for a variety of applications.

Strobe Selection

Proper selection of ceiling mount visible notification appliances is dependent on occupancy, location, local codes, and proper applications of: the *National Fire Alarm Code* (NFPA 72), ANSI A117.1, the appropriate model building code, BOCA, ICBO, or SBCCI, and the application guidelines of the Americans with Disabilities Act (ADA).

* Refer to page 2 for guard listing. This product has been approved by the California State Fire Marshal (CSFM) pursuant to Section 13144.1 of the California Health and Safety Code. See CSFM Listing 7125-0026:248 for allowable values and/or conditions concerning material presented in this document. It is subject to re-examination, revision, and possible cancellation. Accepted for use – City of New York Department of Buildings – MEA35-93E. This product was not ULC listed or FM approved as of document revision date. Additional listings may be applicable, contact Simplex for the latest status. Additional listings may be applicable; contact your local Simplex product supplier for the latest status. Listings and approvals under Simplex Time Recorder Co. are the property of Tyco Safety Products Westminster.

** Two-wire synchronization circuit operation is protected by U.S. Patent No. 5,559,492. SmartSync horn/strobe operation is protected under U.S. Patent No. 6,281,789.

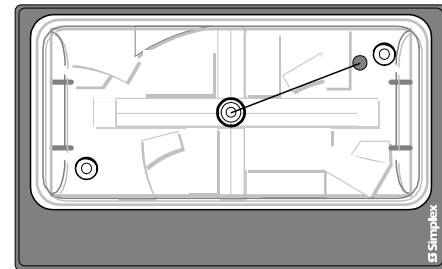

Ceiling Mount Strobes are Available in Red with White Lettering and White without Lettering (side view and front view shown)

Synchronized Strobes

When multiple strobes and their reflections can be seen from one location, synchronized flashes reduce the probability of photo-sensitive reactions as well as the annoyance and possible distraction of random flashing. If synch output NACs are not available, two-wire circuit Flash Synchronization Modules can be used to control synchronized flash strobes. (Refer to data sheet S4905-0003 for additional details.) Free-run model strobes will flash in a free-run mode when connected to a synchronized NAC.

SmartSync Control Reference

When selected for synchronized flash mode, these strobes may be controlled by either a synch strobe control or by SmartSync two-wire horn/strobe control.

SmartSync two-wire horn/strobe control, as well as synch strobe only control, is available from:

- 4006, 4008, 4100U, and 4010 Fire Alarm Control Panels (refer to individual product data sheets for details)
- 4009 IDNet™ NAC Extenders, (refer to data sheet S4009-0002)
- SmartSync Control Module (SCM) 4905-9938, which provides a SmartSync interface to conventional NACs (refer to data sheet S4905-0003 for additional details)

Additional SmartSync compatible products include separate horns and combination horn/strobe Audible/Visible notification appliances.

Product Selection

Ceiling Mount Visible Notification Appliances (Strobes)

Model Number	Strobe Output Rating			Housing Color
	15 cd	30 cd	110 cd	
4904-9183	✓			Red with white "FIRE" lettering
4904-9184		✓		
4904-9185			✓	
4904-9345	✓			White without lettering
4904-9346		✓		

Adapter

Model	Description	Dimensions
4905-9910	Surface mount adapter plate, zinc plated, see illustration below	4-7/8" x 3-1/8" (124 mm x 79 mm)

Synchronization Modules (Refer to data sheet S4905-0003 for additional details)

Model	Description	Dimensions
4905-9914	Synchronized Flash Module, Class B (Style Y) operation	1-3/8" x 2-7/16" x 13/16" (35 mm x 62 mm x 20 mm)
4905-9922	Synchronized Flash Module, Class A (Style Z) operation	
4905-9938	SmartSync Control Module, Class A or Class B (Style Z/Y), installs in 4" square box	4" x 4-1/8" x 1-1/4" D (102 mm x 105 mm x 32 mm)

Wire Guard (see illustration below)

Model	Description	Dimensions
4905-9926	Red Wire Guard (UL listed by Space Age Electronics Inc.)	6-1/8" x 4-3/8" x 2-7/8" deep (156 mm x 111 mm x 73 mm)

Surface/Semi-Flush Installation Reference

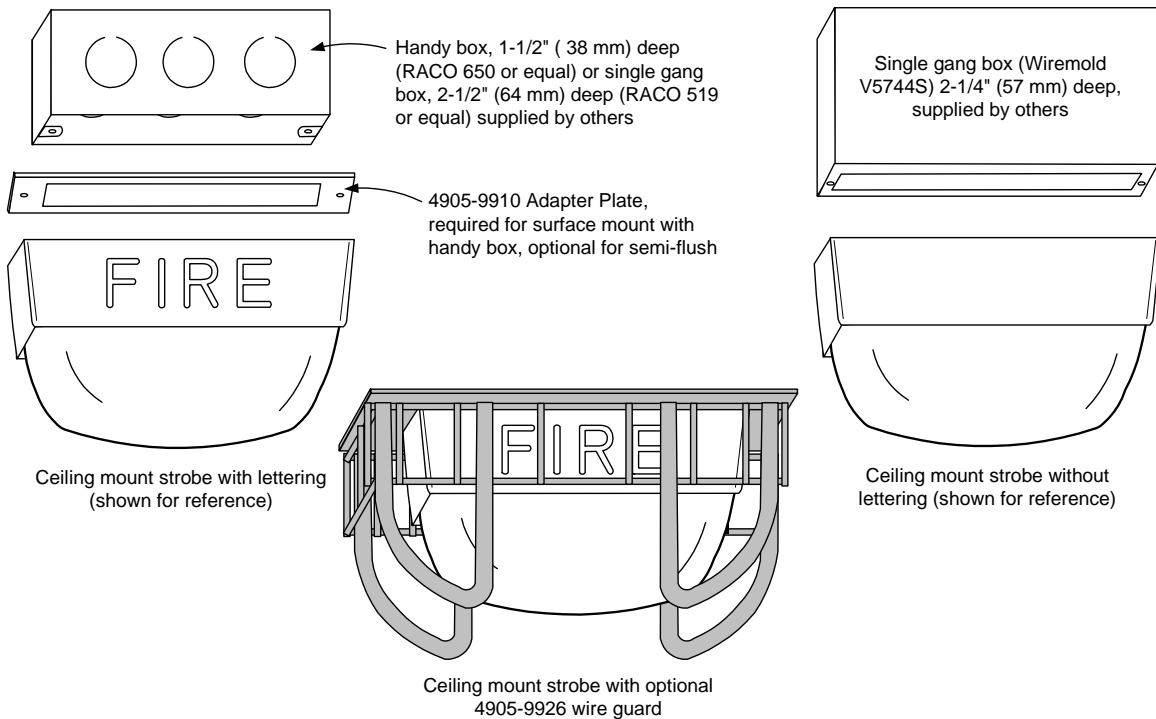

Specifications

General Specifications

Rated Voltage Range	Regulated 24 VDC; see Note 1 below
Housing Dimensions (including lens)	4-3/4" x 2-5/16" x 2-5/8" D (121 mm x 75 mm x 67 mm)
Temperature Range	32° to 122° F (0° to 50° C)
Humidity Range	10% to 93%, non-condensing at 100° F (38° C)
Connections	Terminal blocks for 18 AWG to 12 AWG (0.82 mm ² to 3.31 mm ²); two wires per terminal for in/out wiring

Strobe Specifications

Flash Rate and Synchronized NAC Loading	1 Hz; with up to 35 synchronized strobes maximum per NAC			
Maximum RMS Current Rating per Strobe Output (see Note 2 below)		15 cd	30 cd	110 cd
		90 mA	128 mA	285 mA
Reference Currents at other voltages	18 VDC	80 mA	114 mA	253 mA
	24 VDC	60 mA	85 mA	190 mA

NOTES:

1. "Regulated 24 VDC" refers to the voltage range of 16 to 33 VDC per UL Standard 1971, Signaling Devices for the Hearing Impaired, changes effective May 1, 2004. This voltage range is the absolute operating range. Operation outside of this range may cause permanent damage to the appliance. Please note that 16 VDC is the lowest operating voltage that is allowed at the last appliance on the NAC under worst case conditions.
2. The maximum RMS current listed is the device nameplate rating. Strobe designs are constant wattage and the maximum RMS current rating occurs at the lowest allowable operating voltage. (RMS is root mean square and refers to the effective value of a varying current waveform.)

T-bar Mounting Reference

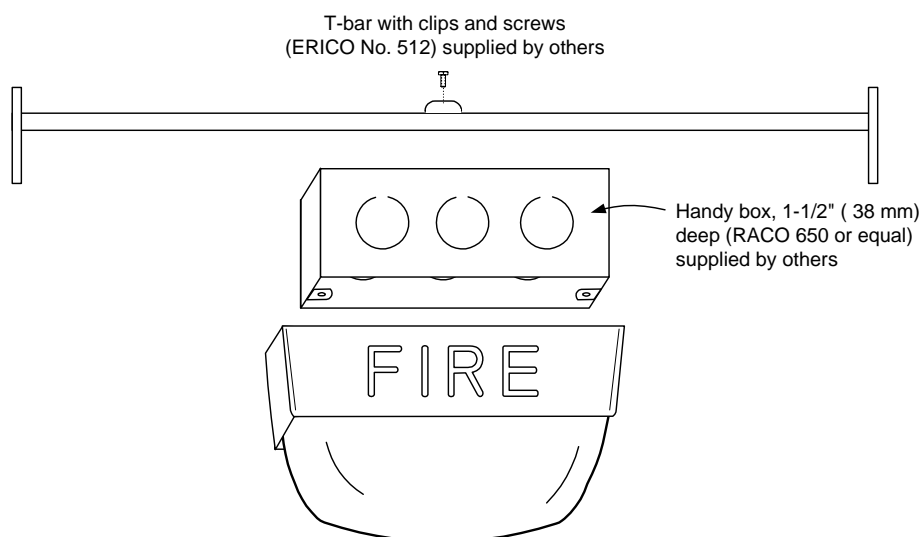

Tyco is a registered trademark of Tyco International Services GmbH and is used under license. Simplex, the Simplex logo, SmartSync and IDNet are trademarks of Tyco International Ltd. and its affiliates and are used under license. NFPA 72 and National Fire Alarm Code are trademarks of the National Fire Protection Association (NFPA). Wiremold is a trademark of the Wiremold Company.



Tyco Safety Products Westminster • Westminster, MA • 01441-0001 • USA

S4904-0009-5 9/2009

www.tycosafetyproducts-usa-wm.com

© 2009 Tyco Safety Products Westminster. All rights reserved. All specifications and other information shown were current as of document revision date and are subject to change without notice.